

Migration from NM7010A to WIZ81xMJ

This documentation mainly describes what H/W designers should consider when migrating from the NM7010A-LF to the WIZ81XMJ. For the information about firmware migration from NM7010A to WIZ81XMJ, please refer to *Migration from W3100 to W3150A+*, because the driver of W3150A+ and W5100 is fully compatible.

In addition, NM7010A-LF has three different versions. The firmware of them is also fully compatible. Users just need to pay more attention on H/W change. This documentation focuses on the migration from NM7010A-LF Rev 2.0 to WIZ81XMJ.

For additional information about the WIZ81XMJ and NM7010A-LF Rev 2.0, refer to the *WIZ81XMJ datasheet* and *NM7010A-LF Datasheet ver 2.6*.

This document contains the following topics:

Topic

Section 1, "Comparison"

Section 2 "Hardware Considerations"

Section 3 "References"

1 Comparison

1.1 Advantages and Challenges of Migration

This section highlights the various advantages and challenges involved when migrating from the NM7010A to the WIZ81XMJ.

Since Ethernet chip is W5100, the WIZ81XMJ provides a higher level of performance while maintaining many characteristics of the NM7010A's architecture. Following is a list of the advantages of migrating to the WIZ81XMJ:

- More cost-effective
- Provides a higher level of integration
- Added Tx free size register and Rx received size register, users can directly read them and don't need to calculate the value by themselves any more.
- TCP sequence and ACK number is automatically processed. Users don't need to calculate the values by themselves any more.
- New functions (PPPoE/IGMP/SPI Interface/Keepalive, etc)

Following is a list of differences that may present challenges in migrating from the NM7010A to the WIZ81XMJ.

- H/W is not 100% compatible

1.2 Summary and Feature Comparison Tables

Table 1 includes information comparing some of the features of the NM7010A and the WIZ81XMJ.

Table 1. NM7010A and WIZ81XMJ Comparison

	NM7010A	WIZ810MJ	WIZ811MJ	WIZ812MJ
Voltage	3.3v			
Function	Ethernet Connectivity			
H/W TCP/IP stack	W3100	W5100		
PHY	RTL8201BL/IP101A-LF			
Protocol	TCP, UDP, IP, ARP, ICMP	TCP, UDP, IP, ARP, ICMP, IGMP, PPPoE,		
PCB Through Hole	none		Two(Ø3.00mm)	Four(Ø3.00mm)
LINK LED	Keep LOW when link is established	Keep LOW when link is established. But HIGH during the data transaction..		Keep LOW when link is established
Connector Type	2x2x14 2mm pin header		2x2x14 2.54mm pin header	
Dimension (mm)	52x25x21		55.5x25x23.5	
Temperature	0~70 °C			

2 Hardware Considerations

From Table 1, we can see that among WIZ81XMJ series the migration from NM7010A to WIZ810MJ needs the minimum H/W change. The same pin-header is mounted, but pin description is different.

However, for migration from NM7010A to WIZ811MJ or WIZ812MJ, it is almost like a new design, since connector is totally different.

Furthermore, in the aspect of functions and performance, WIZ81XMJ is the same. Thus, choosing the easiest one to do migration is the best solution.

2.1 Pin Assignment

- NM7010A Pin assignment

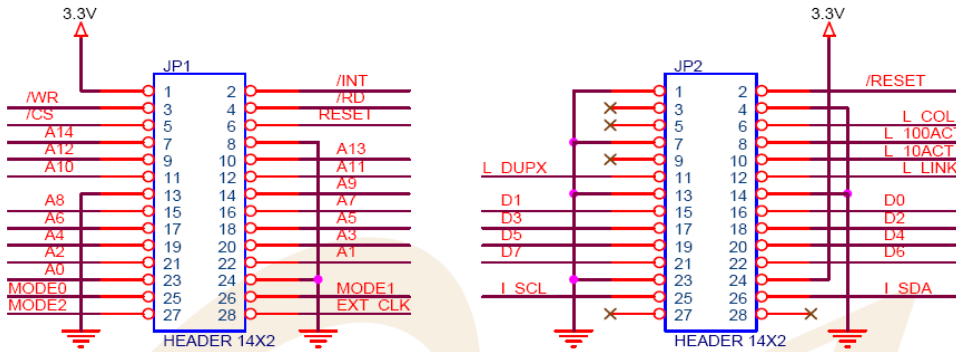

Fig 1 NM7010A Pin assignment

- WIZ810MJ Pin assignment

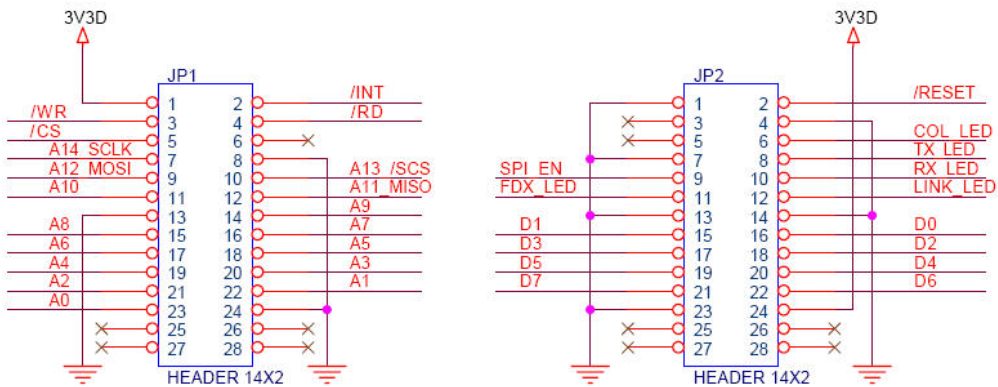

Fig 2 WIZ810MJ Pin assignment

- Migration reference Pin assignment from NM7010A to WIZ810MJ

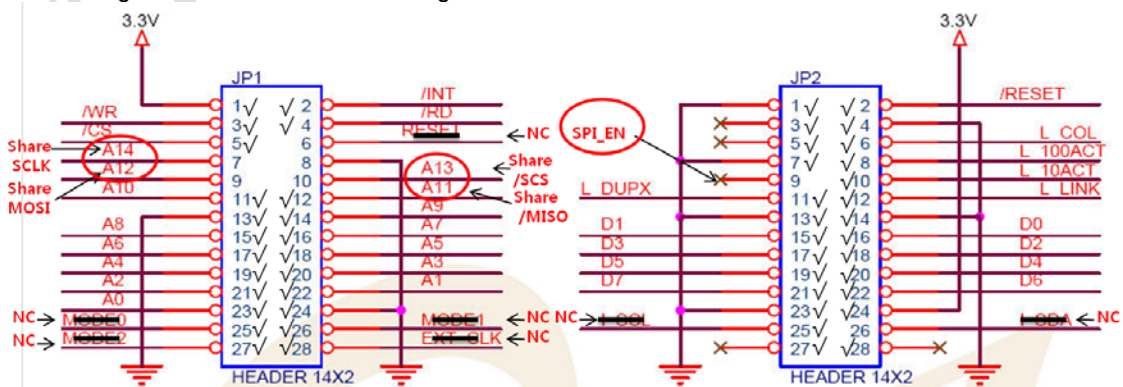

Fig 3 Pin Assignment Considerations when migrate from the NM7010A to WIZ810MJ

- “-” means “removed function”
- “f” means “no change”,
- “←+comments” means “the changed part”

2.2 Summary for H/W change

Table 2 Summary for H/W change

MCU Interface	NM7010A → WIZ810MJ
Direct	JP1.6: WIZ81xMJ requires only one reset signal(/RESET). User doesn't need to handle two kinds of the reset signals.
Indirect	JP1.25~28: WIZ81xMJ generates clock signal internally. So these pins will not influence on new module because they are NC pins.
I2C	WIZ81xMJ doesn't support I2C interface. However if your MCU supports SPI interface, you can use WIZ81xMJ.

3 References

To download User manual and Configtool, refer to below links:

- NM7010A:

Datasheet:

[http://www.wiznet.co.kr/Upload_Files/ReferenceFiles/NM7010A-LF_Datasheet_V2.6\[0\].pdf](http://www.wiznet.co.kr/Upload_Files/ReferenceFiles/NM7010A-LF_Datasheet_V2.6[0].pdf)

Hardware schematic:

[http://www.wiznet.co.kr/Upload_Files/ReferenceFiles/NM7010A-LF_Rev.2.0_schematic_20070719\[1\].pdf](http://www.wiznet.co.kr/Upload_Files/ReferenceFiles/NM7010A-LF_Rev.2.0_schematic_20070719[1].pdf)

- WIZ810MJ:

Datasheet:

http://www.wiznet.co.kr/Upload_Files/ReferenceFiles/WIZ810MJ_Datasheet_V_1.2.pdf

Hardware schematic:

http://www.wiznet.co.kr/Upload_Files/ReferenceFiles/WIZ810MJ_sche_REV1.1.pdf

- WIZ811MJ

Datasheet:

http://www.wiznet.co.kr/Upload_Files/ReferenceFiles/WIZ811MJ_Datasheet_V_1.1.pdf

Hardware schematic

http://www.wiznet.co.kr/Upload_Files/ReferenceFiles/SCHEMATICs_811MJ.zip

- WIZ812MJ

Datasheet:

[http://www.wiznet.co.kr/Upload_Files/ReferenceFiles/WIZ812MJ_Datasheet_V_1.1\[1\].pdf](http://www.wiznet.co.kr/Upload_Files/ReferenceFiles/WIZ812MJ_Datasheet_V_1.1[1].pdf)

Hardware schematic

http://www.wiznet.co.kr/Upload_Files/ReferenceFiles/WIZ812MJ_REV1.0.zip

- TCP/UDP loopback testing tool (AX1.exe)

http://www.wiznet.co.kr/Upload_Files/ReferenceFiles/AX1.zip